



Wärtsilä 46F engines

Exceptional fuel flexibility with best-in-class power-to-weight and power-to-space ratios

Wärtsilä 46F engines give you the power to adopt alternative fuels at your own pace. This proven 4-stroke medium-speed engine series offers exceptional flexibility in terms of both power range and fuel choice. Wärtsilä 46F engines are ideal for a wide range of demanding marine applications including large ferries, RoRo vessels and dredgers.

A powerful and efficient platform for decarbonisation

Wärtsilä 46F series engines are based on a common, proven platform that lets you take decarbonisation at your own pace.

There's a flexible dual-fuel variant for LNG use, a methanol-ready variant and a fully methanol-capable variant in addition to a traditional diesel variant.

Choosing the methanol-ready variant for newbuilds puts you in the decarbonisation driving seat because you can launch your ship using other fuels and then convert your engine to use methanol fuel with only minor changes.

Whichever fuel pathway you choose, Wärtsilä 46F engines deliver exceptional efficiency and power density as well as superb reliability and uptime plus compliance with stringent emissions regulations.

Efficient, reliable performance for demanding marine applications

Wärtsilä 46F engines offer the widest fuel flexibility in their power range from 7.5 MW to 20 MW at 600 rpm and are available in 6L to 16V cylinder configurations. The engines also offer exceptional fuel economy with best-in-class power-to-weight and power-to-space ratios, making them the ideal choice for applications with high power demands, such as large ferries, RoRo vessels and dredgers.

Because Wärtsilä 46F engines are based on a common platform, ship owners and operators are free to tailor their own pathway to a low-carbon future with one of the four engine variants:

- **Wärtsilä 46DF** – a dual-fuel engine optimised for LNG, which reduces fuel costs and overall greenhouse gas emissions; can also run on conventional fuels
- **Wärtsilä 46F Methanol-ready** – a traditional diesel engine that can easily be converted to run on methanol because it shares key components with the Wärtsilä 46F Methanol
- **Wärtsilä 46F Methanol** – capable of running on green methanol or conventional fuels, including HFO
- **Wärtsilä 46F Diesel** – for conventional fuels including HFO; can be converted to run on alternative fuels

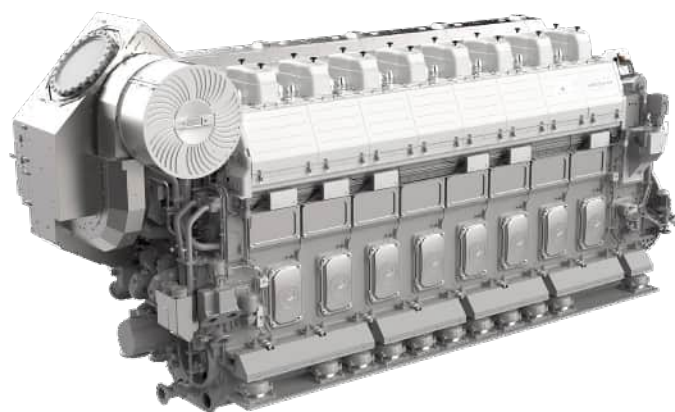

| Wärtsilä 46F Diesel

Key benefits

- Exceptional fuel flexibility from conventional fuels to bio-LNG or green methanol
- Best-in-class power-to-weight and power-to-space ratios
- Optimised fuel consumption at all loads
- Alternative-fuel ready; delivers 100% load in methanol mode, providing 1250 kW per cylinder, maintaining power without sacrificing efficiency
- Extended overhaul intervals to maximise availability
- Modular design reduces inventory costs, maintenance and crew training time
- Proven engine platform with over 18 years of operational history and more than 7 million running hours

Alternative-fuel ready for emission reduction and regulatory compliance

Wärtsilä 46F engines are IMO Tier II compatible and the dual-fuel LNG engine is IMO Tier III compatible in gas mode. With a selective catalytic reduction (SCR) system you can reach IMO Tier III with all Wärtsilä 46F variants. These modular engines can be adapted easily to meet changing regulatory requirements without significant modifications even if you start with a traditional diesel engine.

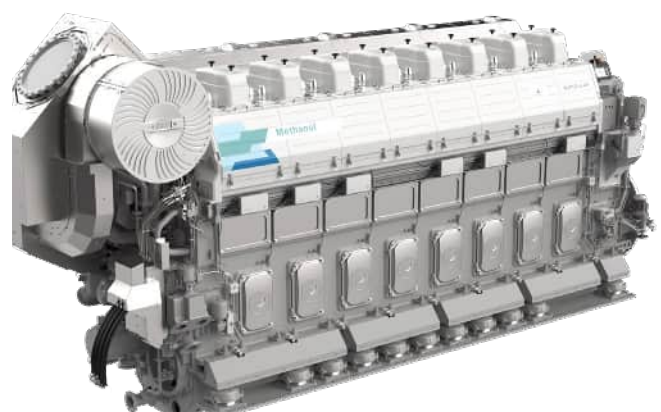

| Wärtsilä 46F Methanol



The reliable Wärtsilä 46F engine platform offers an ideal basis for methanol-fuelled operations. The Wärtsilä 46F methanol-ready and methanol engines:

- provide the same power in pure diesel mode as in methanol mode,
- can also operate on conventional fuels,
- deliver seamless fuel switching between methanol and conventional fuel operation.

To future-proof your newbuild vessel, choose the Wärtsilä 46F methanol-ready or methanol engine. Ensure in the design that your vessel is already equipped with or can later easily be fitted with a methanol fuel supply system, including fuel tanks and piping etc. If green methanol fuel is not available, you can still launch your vessel as planned because it can use other fuels and still deliver the same high-power performance.

Optimised combustion and fuel consumption

Wärtsilä 46F engines feature a robust, reliable single-stage turbocharger plus variable valve timing to optimise combustion and reduce emissions at part load. The advanced fuel-injection system allows for different injection timing, optimising fuel consumption at each load.

Less complex installation and maintenance

The optional built-in lube oil module reduces the need for piping, which simplifies the engine room arrangement and allows engine automation to control lube oil temperature.

Automatic periodic cleaning of charge air coolers with the Wärtsilä Delta Cleaner reduces maintenance needs by removing the need to replace coolers. Additionally, the turbocharger design is based on a cartridge concept to enable faster overhauls.

Wärtsilä 46F, Wärtsilä 46F Methanol and Wärtsilä 46DF

Wärtsilä 46F			
	Diesel	Methanol	Dual-fuel
Cylinder output (kW/cyl)	1250		1145
Cylinder bore / Piston stroke (mm)	460 / 580		
Engine speed (rpm)	600		
Fuel types	LFO, HFO, LBF, low & ultra-low sulphur fuels	MeOH, HFO, LFO, LBF, low & ultra-low sulphur fuels	LNG, LFO, HFO, LBF, low & ultra-low sulphur fuels
Emission standard	IMO Tier II IMO Tier III (with SCR)		IMO Tier III IMO Tier II in diesel mode w/o SCR
Optional feature	Lubricating oil module integrated in engine		

Wärtsilä 46F and Wärtsilä 46F Methanol

Engine dimensions (mm) and weights (tonnes)							
Engine type	A*	A	B	F	C	Weight ** Wärtsilä 46F	Weight ** Wärtsilä 46F Methanol
6L	8720	8880	3540	1430	2750	102	103
7L	9540	9720	3730	1430	3060	114	115
8L	10360	10540	3730	1430	3060	128	129
9L	11180	11360	3730	1430	3060	143	144
12V	11280	10460	3860	1620	4560	177	178
14V	12410	11590	4070	1620	5180	205	206
16V	13460	12640	4070	1620	5180	224	225

A* Turbocharger at driving end

A Turbocharger at free end

** Dry weight of rigidly mounted engine without flywheel

Wärtsilä 46DF

Engine dimensions (mm) and weights (tonnes)						
Engine type	A*	A	B	F	C	Weight **
6L	8610	8550	3460	1480	2710	108
7L	9430	9370	3460	1480	2710	121
8L	10350	10520	3570	1480	3100	133
9L	11170	11340	3570	1480	3100	146
12V	11280	10460	3870	1620	4560	180
14V	12330	11510	3870	1620	4560	207
16V	13580	12530	4070	1620	5180	231

A* Turbocharger at driving end

A Turbocharger at free end

** Dry weight of rigidly mounted engine without flywheel

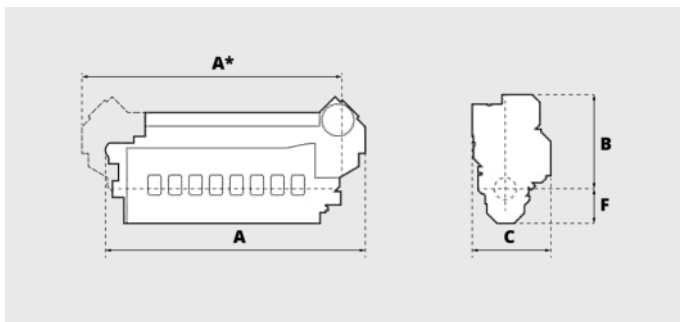

Work with Wärtsilä to navigate decarbonisation with confidence.

Build your success on Wärtsilä's broad portfolio of engines, propulsion systems, hybrid technology, exhaust treatment, shaft line solutions and digital technologies, as well as integrated powertrain systems. These building blocks offer you efficiency, reliability, safety and world-class environmental performance.

The offering includes performance-based agreements, lifecycle solutions and an unrivalled global network of maritime expertise.

www.wartsila.com/marine



Wärtsilä is a global leader in innovative technologies and lifecycle solutions for the marine and energy markets. We emphasise innovation in sustainable technology and services to help our customers continuously improve their environmental and economic performance.

© 2024 Wärtsilä Corporation – All rights reserved.

No part of this publication may be reproduced or copied in any form or by any means (electronic, mechanical, graphic, photocopying, recording, taping or other information retrieval systems) without the prior written permission of the copyright holder. Neither Wärtsilä Finland Oy, nor any other Wärtsilä Group Company, makes any representation or warranty (express or implied) in this publication and neither Wärtsilä Finland Oy, nor any other Wärtsilä Group Company, assumes any responsibility for the correctness, errors or omissions of information contained herein. Information in this publication is subject to change without notice. No liability, whether direct, indirect, special, incidental or consequential, is assumed with respect to the information contained herein. This publication is intended for information purposes only.