

Less Emissions Through Waste Heat Recovery

Heinrich Schmid
 Manager, Application Technology, Ship Power
 Wärtsilä Switzerland Ltd, Winterthur

Summary

Current interest in reducing emissions and reducing engine operating costs is leading towards the use of more effective waste heat recovery. By adapting the tuning of the Sulzer low-speed two-stroke marine engines to increase exhaust gas energy and employing both steam and exhaust gas turbines in a Total Heat Recover Plant, an electrical output of about 11% of engine power is possible. Such savings can make a major contribution to improving both plant efficiency and engine emissions. For example, with a Sulzer 12RTA96C engine, as widely applied in today's large container liners, the Total Heat Recovery Plant would provide up to 7000 kW as electrical power at the engine's service load.

This Total Heat Recovery Plant is attracting much interest from shipowners interested in saving fuel costs and reducing emissions. It must be remembered that modern large, low-speed marine engines are very highly developed and there is little potential for achieving significant reductions in CO₂ emissions by engine development alone. Thus the proposed Total Heat Recovery Plant is a practical path forward.

Introduction - Why waste heat recovery?

Much has already been published about reducing exhaust gas emissions from marine diesel engines with attention being on either controlling the generation of the emissions inside engine cylinders, removing the emissions by aftertreatment of the exhaust gases, or in the case of SO_x emissions restricting the fuel specification. Yet when it will be necessary to address the reduction in carbon dioxide (CO₂) emissions, we will most probably need to spread our net further when looking for further emissions-control ideas.

It has to be recognised that there is very little margin left in the large marine diesel engine for reducing CO₂ emissions through improving engine thermal efficiency. After the 1973 Oil Crisis, considerable investment was put into reducing engine fuel consumption with the result that for some years the largest-bore engines have had an overall thermal efficiency of almost 50% (Fig.1).

In any case, an important factor now is that there is a natural trade-off between engine fuel consumption and NO_x emissions. Reductions in specific fuel consumption involve a natural increase in NO_x emissions.

Yet there is one avenue which give both a reduction in emissions and a reduction in fuel consumption – utilisation of otherwise wasted energy. With today's modern low-speed engines having an excellent efficiency of up to 50%, there is still 50% of the fuel input energy not being put to productive use.

In the case of a Sulzer 12RTA96C engine developing a maximum continuous output of 68,640 kW, this means that an equivalent quantity of energy is being wasted. A

daily consumption of about 300 tonnes of heavy fuel oil is needed to generate this 68,640 kW shaft power. It is needless to say that the wasted energy is burdening the environment and is wasting our limited primary energy resources. We do have the responsibility to take care of the environment and to make best use of our primary energy resources. This leads to the need to develop concepts which allow better utilisation of primary energy.

*Fig. 1: Heat balance of a Sulzer 12RTA96C engine shows the potential for waste heat recovery with current large, low-speed marine engines.
 [04#037]*

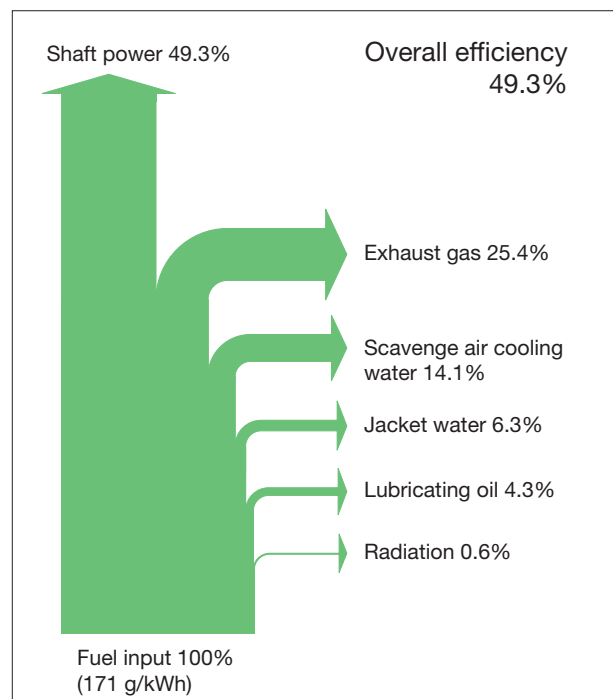

* This paper was presented at the Green Ship Technology Conference, London, 28/29 April 2004.

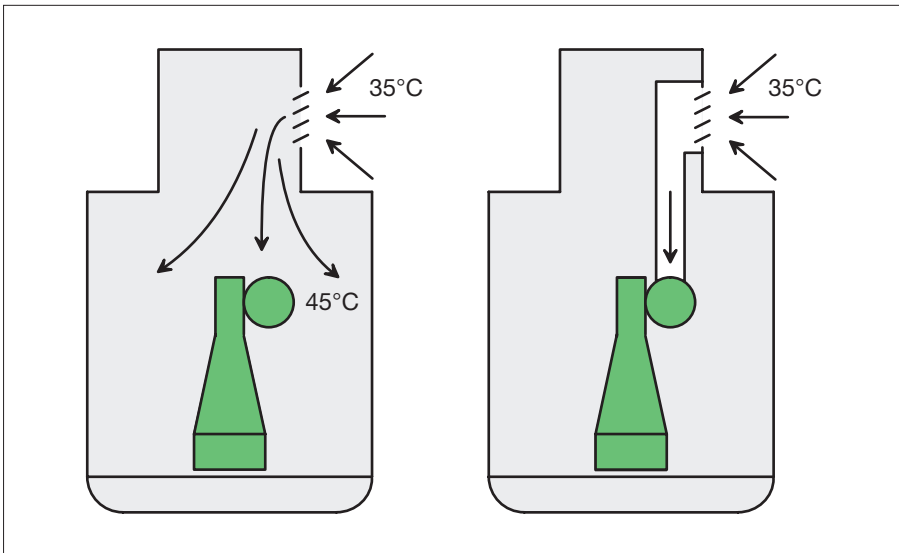

Fig. 2
 Far left: Engine room air suction.
 Left: Ambient air suction.
 [04#038]

Improved utilisation of fuel energy at the end of the day results in both lower fuel costs and lower emissions. The reduced emissions also have the benefit of providing the vessel with a 'green' image which today is even becoming a helpful factor in the competition of the freight market.

The application of a waste heat recovery system is therefore threefold:

- The operator profits from a lower annual fuel bill
- The operator contributes to lower the emission, such as CO₂ and NO_x
- The operator benefits from an improved competitiveness in the freight market.

There is also the moral point in that the industry has an obligation to carefully deal with the Earth's limited energy resources and, at the same time, look for environmentally-friendly solutions.

Engine tuning for waste heat recovery

In the engine's exhaust gases about 25% of the input energy is available at a fairly high temperature (Fig. 1). They are therefore a useful, potential source for heat recovery.

Yet this exhaust gas temperature can be increased by adapting the engine for ambient suction air intake. Usually marine engines are designed for intake temperatures of up to 45°C for tropical conditions with turbochargers drawing intake air from the engine room. If instead the intake air is drawn from outside the engine room through an air intake duct, the maximum intake temperature can be assumed to be no more than 35°C (Fig.2).

In such a case, the turbochargers can be rematched to return the thermal load of the engine back down to what prevails for the intake temperature at 45°C. When considering such a tuning to reach an increased exhaust gas temperature, it is important that the thermal load of the adapted engine is no greater than that of the usual engine so as not to jeopardise engine reliability.

Even with a certain quantity of exhaust gas branched

off for the power turbine and therefore not then available for the turbocharger, the thermal loading of the engine becomes even lower than for the conventional engine (Fig. 3). This is possible because the special turbocharger matching in combination with the power turbine allows full utilisation of the available efficiency of the turbocharger, and also because of the ambient suction tuning.

This adapted tuning, however, incurs a penalty in a slightly increased fuel consumption at ISO reference conditions. But the gain in recovered energy more than compensates for the loss in efficiency from the higher fuel consumption. The engine needs to be equipped with an air waste gate to ensure that the maximum cylinder pressure stays within permissible limits at very low ambient temperature.

Modern, high-efficiency turbochargers also have a small surplus in efficiency capability in the upper load range. This allows a certain exhaust gas flow to be branched off before the turbocharger to drive a gas turbine, or as it is called in this application a power turbine. With normal engine tuning it is not worth taking advantage of this possibility. However, the rematched turbochargers for ambient suction allow even more exhaust gas to be branched off under ISO conditions compared with the conventional tuning with maximum 45°C suction air temperature. Therefore, the rematched engine supercharging system gives an increased exhaust gas temperature and allows a good amount of exhaust gas to be branched off before the turbocharger thereby allowing a worthwhile heat recovery potential to be achieved.

Total Heat Recovery Plant

The proposed Total Heat Recovery Plant consists of a dual-pressure economiser, a multiple-stage dual-pressure steam turbine, a power turbine, an alternator driven by both the steam turbine and the power turbine, a feed water pre-heating system and a shaft motor/alternator system (Fig. 4).

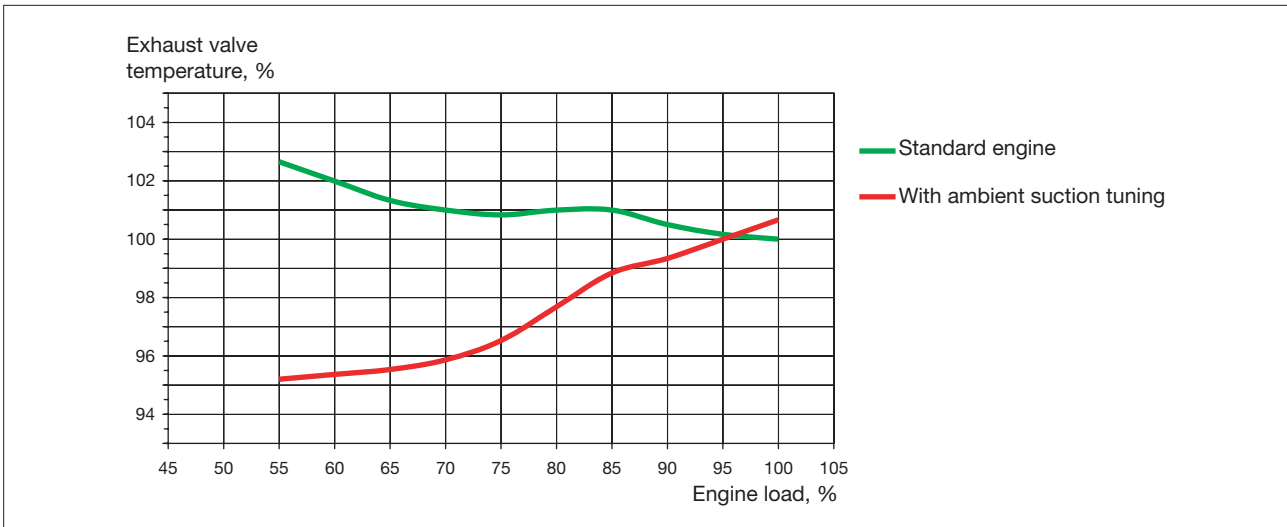

Fig. 3: Thermal loading of the engine with conventional tuning compared with that obtained when tuned for the Total Heat Recovery Plant as represented by the exhaust valve temperature for the 12RT-flex96C engine. [04#039]

Exhaust gas economiser

The exhaust gas economiser consists of a high-pressure part with HP evaporator and superheating section and a low-pressure part with LP evaporator and superheating section. The pressure in the high-pressure steam drum is at about 9.5 bar(g) pressure. The economiser outlet temperature is not less than 160°C to avoid sulphur corrosion in the economiser outlet. With a pinch point of 10 degrees centigrade, a pressure of about 3.8 bar(g) in the low-pressure steam drum is achieved (Fig. 5).

Saturated steam is drawn from the HP steam drum for ship service heating.

Feed water heating

In a first stage, the feed water is heated from the engine’s jacket cooling water to a temperature of 85°C. Only the feed water for the high-pressure section is further heated in the engine’s scavenge air cooler to about 150°C to 170°C. The scavenge air cooler is designed such that the feed

water heating section can run dry with the total scavenge heat dissipated in the scavenge air cooler.

Turbogenerator

A dual-pressure steam turbine running at 6750 rev/min is used. The high-pressure side works at about 8.5–9.5 bar(g) inlet pressure. This requires three stages at a condenser pressure of 0.065 bar. The low pressure is determined by the selected economiser outlet temperature by respecting a pinch point of about 10 degrees centigrade. With an economiser outlet temperature of 160°C, a low-pressure steam pressure at the turbine inlet of 3.0–3.5 bar(g) pressure is considered. This requires six turbine stages at a condenser pressure of 0.065 bar. A speed-reduction gear between steam turbine and generator reduces the turbine speed to 1800 rev/min generator speed.

The power turbine feeds the generated power through a speed reduction gear and an overrunning clutch into the steam turbine (Fig. 6).

Fig. 4: Schematic of the Total Heat Recovery Plant. [04#040]

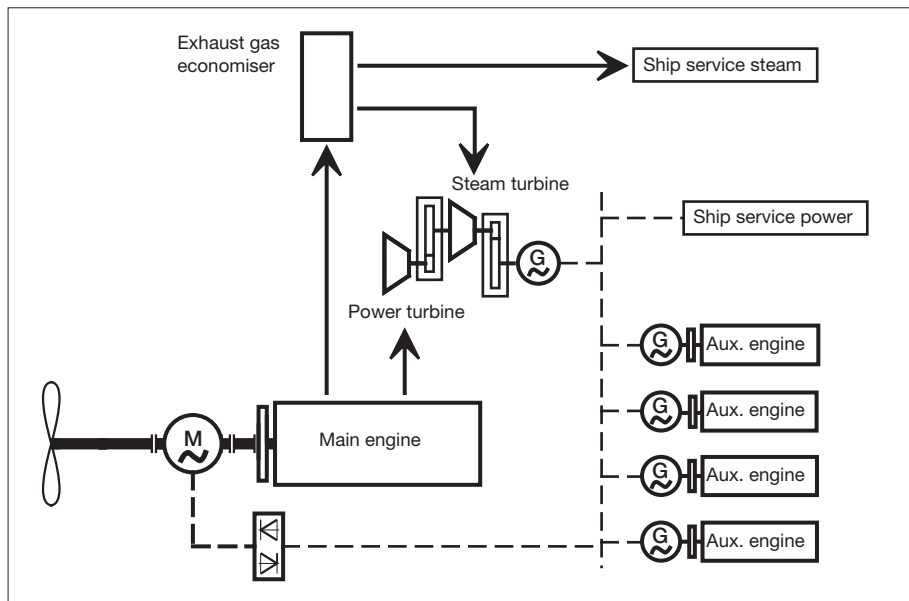

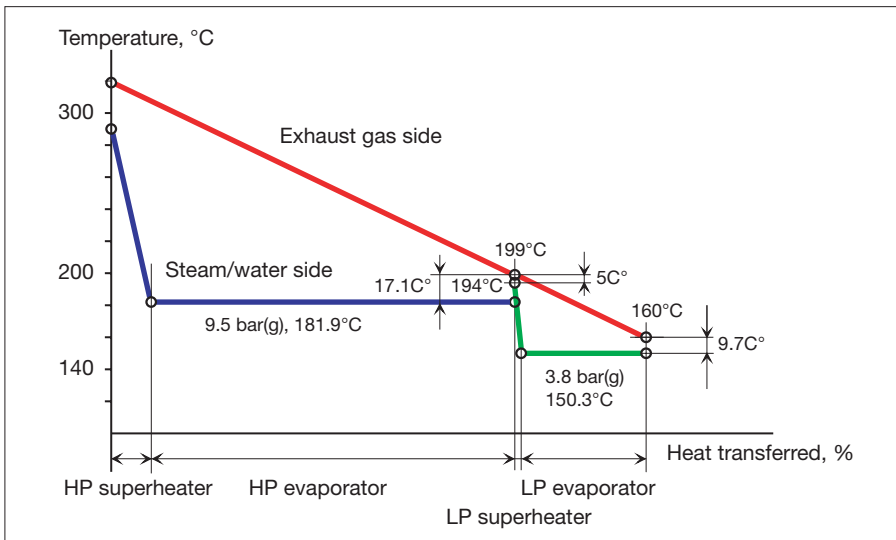

Fig. 5:
Typical economiser diagram for
the Total Heat Recovery Plant.
[04#041]

Power turbine

The power turbine uses a part of the exhaust gas stream (about 10%) from the diesel engine to generate shaft power which can be added to the steam turbine driving the generator. The turbine is a derivative of a well-proven model of turbocharger turbine with minor adaptations for use as a power turbine. A special matching of the power turbine is necessary for the application in a waste heat recovery system because the turbine operates on a constant-speed operating profile as it is coupled to the generator unlike in a turbocharger with a free-running rotor. The torque of the power turbine is fed to the steam turbine rotor through a reduction gear and an overrunning clutch. The overrunning clutch is needed to protect the power turbine from overspeeding in case the generator trips.

The power turbine operates between 55% and 100% engine load. The flow of exhaust gas from the exhaust gas manifold is controlled by an orifice at the outlet of the exhaust gas manifold. At less than 55% engine load, the gas flow to the power turbine is shut off as the

efficiency of the turbochargers at less than 55% load is not sufficiently high and therefore does not allow exhaust gas to be branched off to drive a power turbine. As the power turbine has about the same expansion ratio and efficiency as the turbochargers of the engine, the outlet temperature of the exhaust gas is about the same as from the turbochargers. The gas flow to the power turbine is thus controlled to operate in a number of modes (Fig. 7).

Waste gate

The engine is tuned to operate within the intake temperature range of -5°C to 35°C . The engine maximum pressure stays within the permissible range when the engine operates within this intake suction temperature range. If the ship shall be operated at ambient temperatures below -5°C , the engine has to be protected from excessive maximum cylinder pressure occurring owing to the high specific density of the cold air. This can be achieved by applying a waste gate (blow-off valve) for either scavenge air or exhaust gas.

Although an exhaust waste gate offers certain

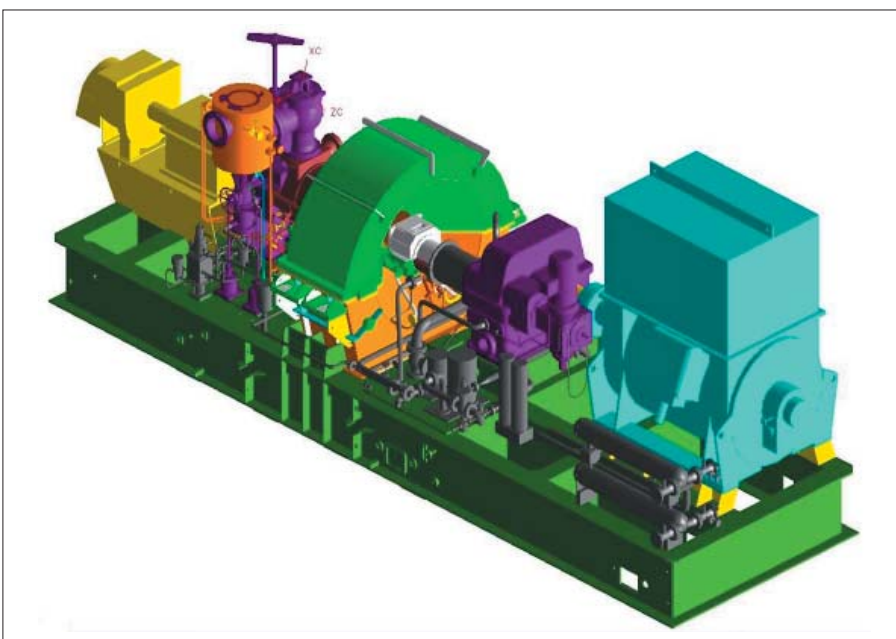

Fig. 6:
Turbogenerator arrangement as
proposed for about 7MWe output
by Peter Brotherhood Ltd. The
complete set measures
about 9.5m long.
[04#042]

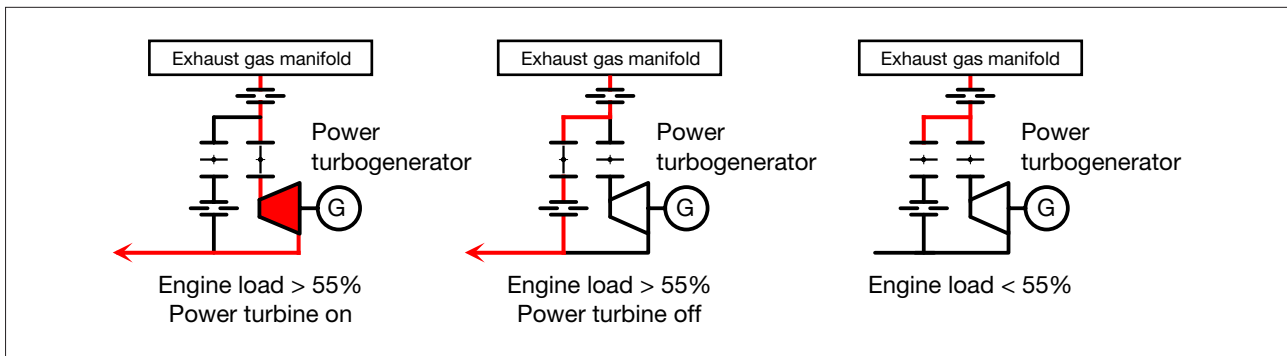

Fig. 7: Operating modes for the exhaust gas power turbine. [04#043]

thermodynamic advantages, the best choice is a scavenge air waste gate because it offers a much higher reliability by avoiding contact with high-temperature exhaust gas. The valve operates on a simple on/off function. If the ambient air temperature drops below -5°C , the waste gate opens and scavenge air is diverted to the air inlet pipe.

Shaft motor/alternator system

The shaft motor/alternator is of the low-speed type, directly mounted in the propeller shaft line (Fig. 8). It operates on variable electrical supply frequency. A frequency control system controls the frequency to and from the electrical supply. The system operates on 6600V. It is arranged to operate as either a motor or an alternator.

Operating modes for the Total Heat Recovery Plant are:

A. Motor mode

The heat recovery system generates more electrical power than is needed for shipboard service. The surplus electric power is applied in a motor/alternator adding power to the propeller shaft.

B. Alternator mode

The heat recovery system generates less electrical power than is needed for shipboard service. The missing

electrical power is generated by the motor/alternator system.

C. Booster mode

More propulsion power is needed than what is available from the main engine. The motor/alternator system acts as motor with the required electrical power being generated by the heat recovery system and the auxiliary engines.

Optional operating mode:

D. Emergency propulsion mode

The main engine is disconnected from the propeller shaft. The ship is then propelled by the shaft motor with power supplied from the auxiliary diesel engines.

The system thus offers considerable flexibility in optimising plant operation to minimise operating costs or maximise propulsion power.

The number of auxiliary diesel generating sets can be reduced by employing a heat recovery system. The use of these sets is considerably reduced thereby providing a further potential to reduce operating costs.

Potential of the Total Heat Recovery Plant

The recoverable power depends on engine conditions. The reference conditions are ISO conditions (25°C suction air temperature, 25°C scavenge air cooling water temperature). Increased exhaust gas back pressure and air suction pressure losses, engine fouling and increased suction air temperature result in a higher exhaust gas temperature and therefore in a greater steam turbine output. At the same time, the output of the power turbine becomes less. Also the fuel consumption increases with the changed engine operating conditions.

The engine operating conditions for the Total Heat Recovery Plant are defined as follows:

- A1 = ISO conditions, new engine [Reference conditions]
- A2 = ISO conditions, maximum exhaust gas back pressure and air suction pressure loss
- A3 = ISO conditions, average aged engine
- A4 = ISO conditions, maximum aged engine
- B1 = Tropical conditions, new engine
- B2 = Tropical conditions, maximum exhaust gas back pressure and air suction pressure loss
- B3 = Tropical conditions, average aged engine
- B4 = Tropical conditions, maximum aged engine

Fig. 8: Typical shaft motor/alternator of about 6MWe output installed on the intermediate shaft of a large container ship. (Siemens) [04#044]



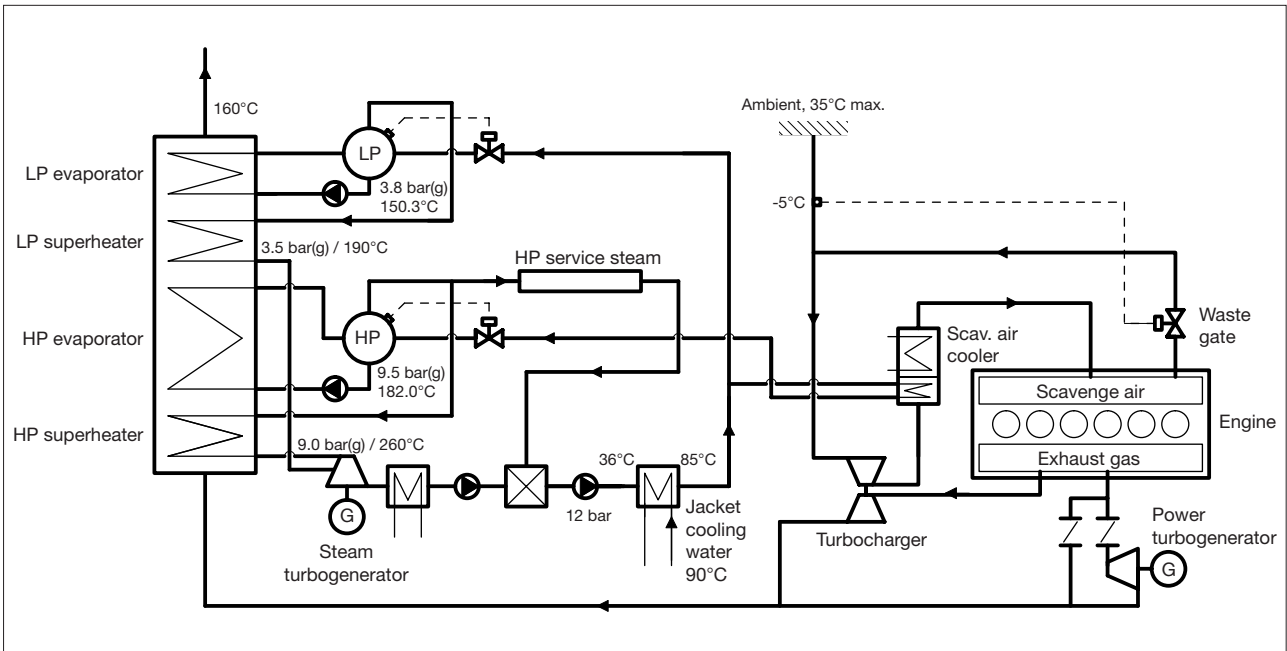

Fig. 9: Process diagram for the Total Heat Recovery Plant. [04#045]

When progressing from operating condition A1 to B4, the following changes can be expected (Fig. 10):

- Specific fuel consumption = + 2.3%
- Steam turbine output = + 25.8%
- Power turbine output = -10.0%

For the economical considerations, normal operation is assumed to be between conditions A3 and B3.

For a Sulzer 12RT-flex96C engine with an MCR power of 68,640 kW this results in a turbogenerator output as shown in figure 11. At 85% engine load, the turbogenerator output is then 7000 kWe. This is 11.0% of the engine power. The engine fuel saving relative to the engine without heat recovery tuning is therefore 10.5%.

The comparison of the heat balances with and without

waste heat recovery can be seen in figure 12.

Combining waste heat recovery with a 14-cylinder Sulzer RT-flex96C engine gives an available service shaft power of 75,658 kW. This is equivalent to an engine MCR power of 89,000 kW (120,000 BHP) for an engine without a heat recovery plant (Table 1). This power should be sufficient to power the next generation of 'mega' container vessels. Such a power is probably also the limit for a single propeller. The application of a Total Heat Recovery Plant to large container vessels gives the benefits of:

- Savings in annual fuel costs
- Environmentally friendly vessel
- Use of proven propulsion machinery

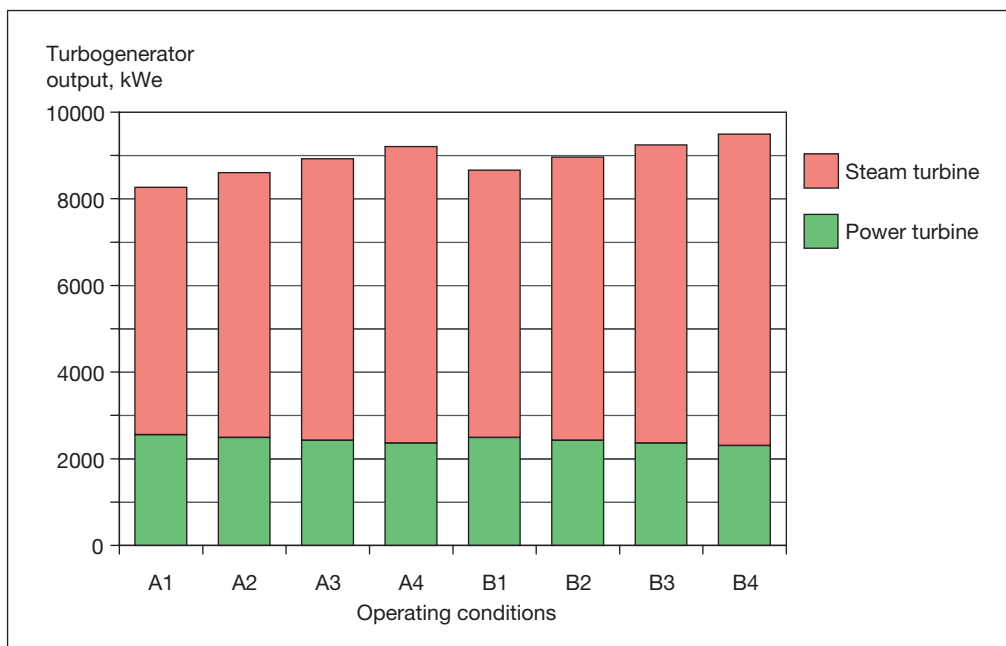

Fig. 10: Steam turbine and power turbine outputs at the various operating conditions, for the Sulzer 12RT-flex96C engine at 100% engine load. [04#046]

Fig. 11:
Recovered power from
a Sulzer 12RT-flex96C
engine, average aged,
average ISO/tropical
conditions.
[04#047]

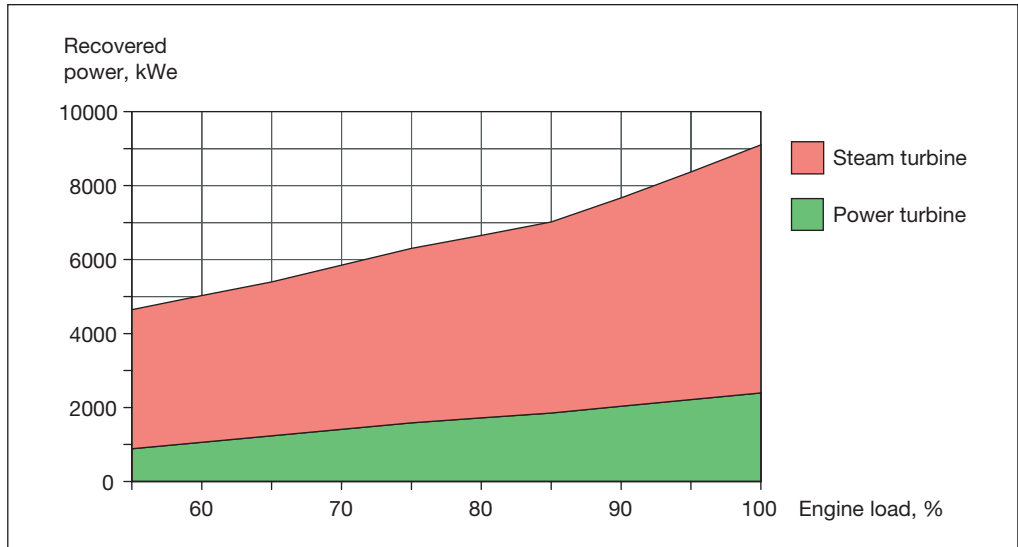
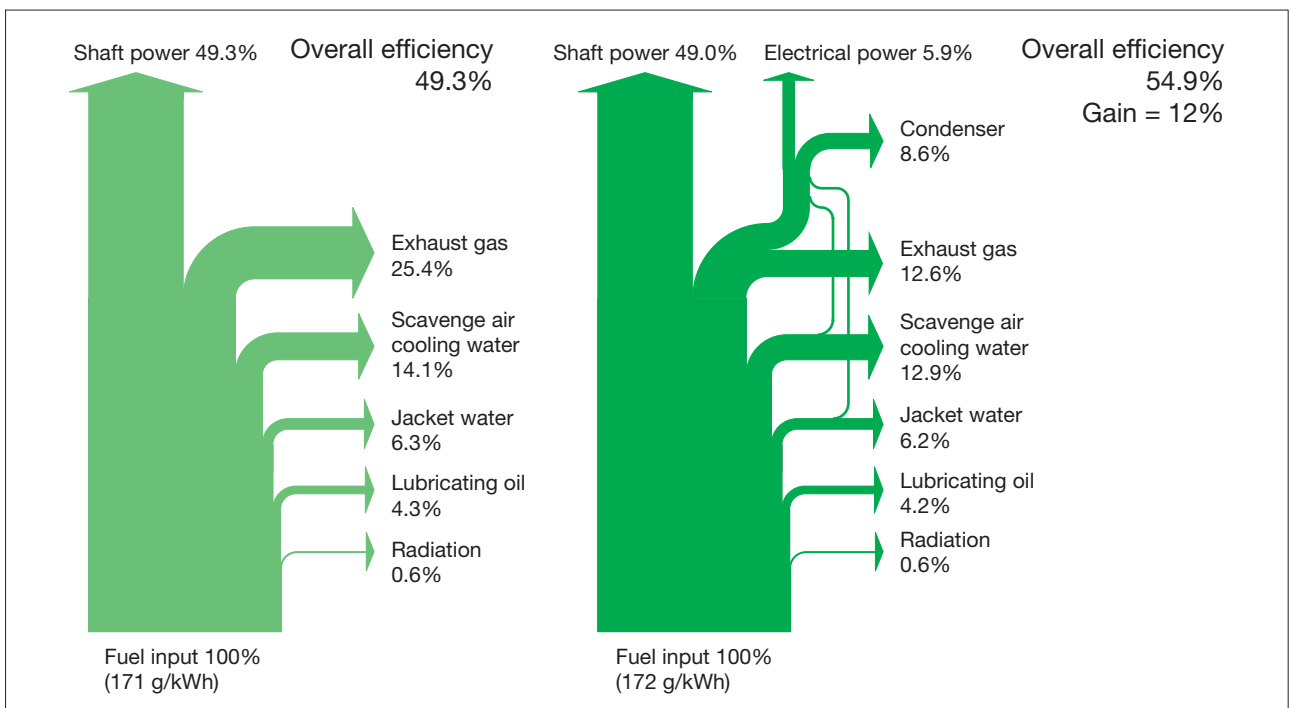

Table 1: Maximum available shaft power with the Total Heat Recovery Plant.

Sulzer engine type	12RT-flex96C	13RT-flex96C	14RT-flex96C
Engine MCR power, kW	68,640	74,360	80,080
Service power at 85% load, kW	58,344	63,206	68,068
Available shaft power* from heat recovery, kW	6,650	7,200	7,590
Total service shaft power, kW	64,994	70,406	75,658
Equivalent engine MCR power without heat recovery, kW	76,460	82,830	89,000

* Assuming a shaft motor efficiency of 95%.

Fig. 12: Comparison of heat balances for Sulzer 12RT-flex96C engines without heat recovery (left) and with the Total Heat Recovery Plant (right) showing the 12% gain in overall efficiency for the Total Heat Recovery Plant.
[04#048]



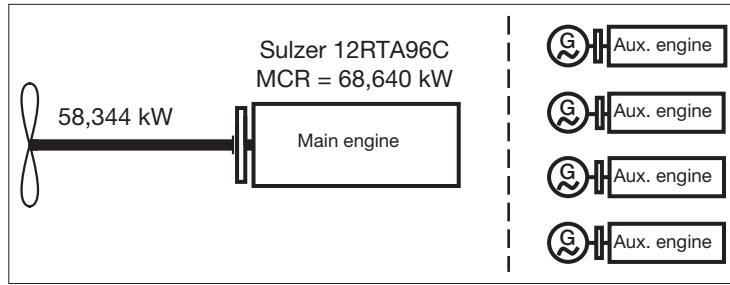

Fig. 13: Schematic of the conventional propulsion plant – the basis.
[04#049]

Economical considerations

To make the Total Heat Recovery Plant attractive, the payback for the investment should not be more than five years.

For a ship propulsion plant consisting of a Sulzer 12RT-flex96C main engine with an MCR power of 68,640 kW and four Wärtsilä 8L32 diesel generating sets, each rated at 3600 kW, the operating cost savings can be estimated on the following basis:

Main engine service load	= 85% load
	= 58,344 kW
Annual operating time	= 6500 hours
Average ship service power	= 4000 kW
Heavy fuel price	= 150 US\$/tonne
Heat value of HFO	= 40,500 kJ/kg

Conventional propulsion plant = basis

Main engine:	
BSFC at service load	= 167.9 g/kWh
Daily HFO fuel consumption	= 247.87 tonnes
Auxiliary engines:	
BSFC at service load (electrical)	= 192.0 g/kWh
Daily HFO fuel consumption	= 19.43 tonnes
Total daily HFO fuel consumption	= 267.30 tonnes
Total annual fuel cost	= US\$ 10,859,062
	= 100%

Propulsion system with Total Heat Recovery Plant

The waste heat recovery plant generates 6740 kW of which 4000 kW are required for ship service, thus 2740 kW giving a shaft power of 2600 kW are available for propulsion.

The main engine service power becomes 55,744 kW (81.2% service load)

BSFC at service load	= 168.5 g/kWh
Daily HFO fuel consumption	= 237.67 tonnes
Annual fuel cost	= US\$ 9,655,343
	= 88.9%

Annual fuel cost saving = US\$ 1,204,000

Maintenance and lubricating oil cost savings:

As the auxiliary engines are not running at sea, the maintenance and lubricating oil costs are reduced with the Total Heat Recovery Plant.

Annual maintenance cost savings	= US\$ 78,000
Annual lub. oil cost savings	= US\$ 47,000

Total annual operating cost savings = US\$ 1,329,000

These annual savings represent a net present value of US\$ 4.6 million, assuming an interest rate of 6% and a payback time of four years. It is very feasible to finance the additional investments for the Total Heat Recovery Plant on this basis.

Fig. 14: Schematic of the propulsion system with the Total Heat Recovery Plant.
[04#050]

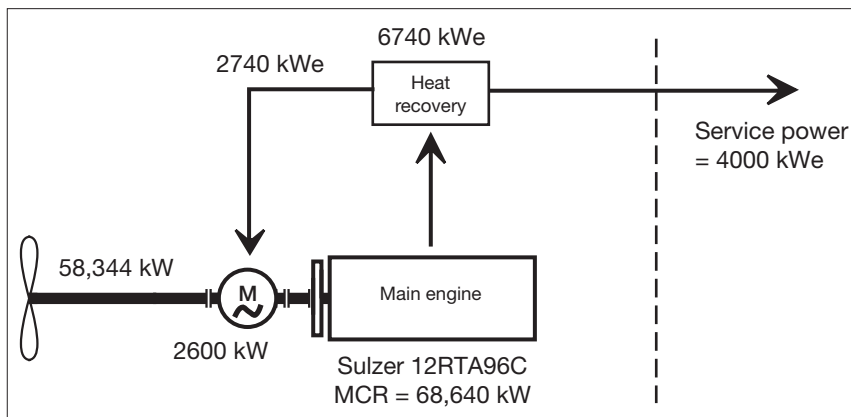
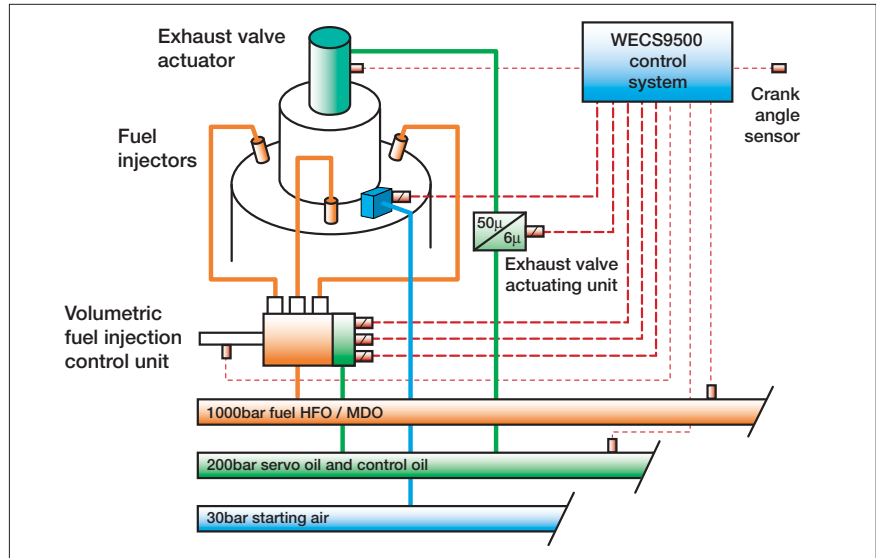

Fig. 15:
Schematic of the common-rail system in Sulzer RT-flex engines.
[02#007]



Sulzer RT-flex common-rail engines for waste heat recovery

The above exposition of the Total Heat Recovery Plant is based on the use of Sulzer RT-flex common-rail engines. The RT-flex engines are especially suitable for waste heat recovery applications because they have the benefit of clean combustion over the entire load range. Therefore much less boiler fouling has to be expected and the consequent risk for a boiler fire is minimum.

The Sulzer RT-flex engine is based on the well-established Sulzer RTA-series engines but instead of the usual mechanically-controlled fuel injection pumps and exhaust valve drives, RT-flex engines have an electronically-controlled common-rail system in which fuel oil, servo oil and control oil are delivered at regulated pressures to rail pipes arranged in a rail unit along the

side of the cylinders (Fig. 15). Heated fuel oil is delivered, ready for injection, at pressures up to 1000 bar. Servo oil and control oil are both at 200 bar and are passed through an automatic self-cleaning fine filter.

Fuel injection and exhaust valve operation are controlled by individual control units for each cylinder. The control units are directly mounted on the single-piece rail pipes and are controlled through Sulzer electro-hydraulic rail valves.

Fuel oil and servo oil are supplied to the common-rail system from the supply unit mounted on the side of the engine column. The supply unit is driven through gearing from the crankshaft. Fuel delivery volume and rail pressure are regulated through suction control of the fuel supply pumps.

The most visible benefit of Sulzer RT-flex engines is

Fig. 16:
Smoke measurements from the Sulzer 6RT-flex58T-B of the 'Gypsum Centennial' during sea trials, compared with an equivalent Sulzer RTA engine. According to a combinator characteristic.
[02#010]

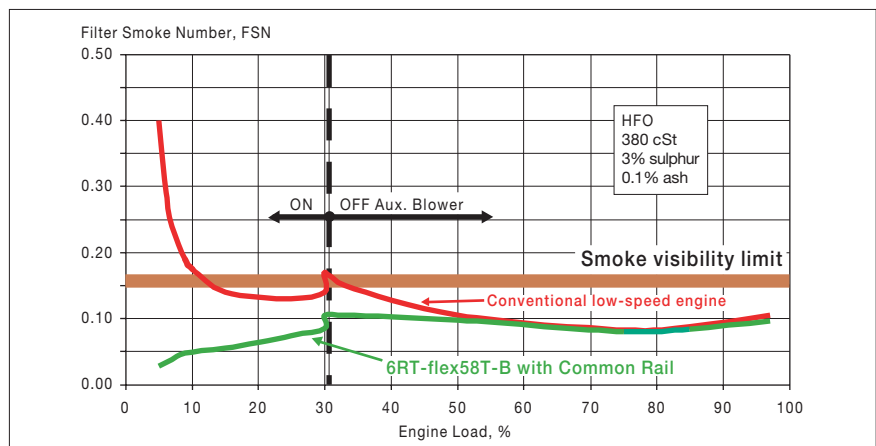

Fig. 17:
Sulzer RT-flex engines are unique in that individual fuel injectors can be cut out as required. At most engine speeds the engines operate on all fuel injectors acting in unison in each cylinder. As speed is reduced, at first one injection valve is shut off and then at very low load speeds another injection valve is shut off leaving the engine running on all cylinders but with just one injector in operation in each cylinder.
[03#118]

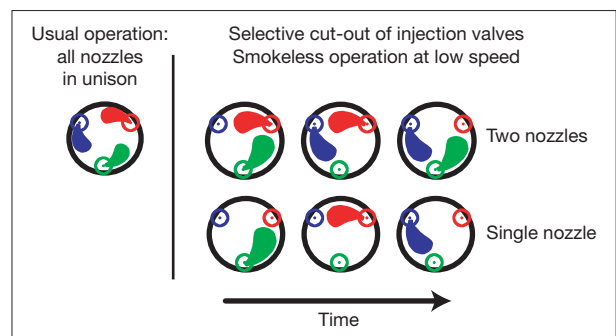



Fig. 18: The first Sulzer RT-flex96C common-rail engine: an 8RT-flex96C of 45,760 kW at 102 rev/min. [04#054]

their smokeless operation at all operating speeds (Fig. 16). This is ensured by the superior combustion possible with the common-rail system. It allows the fuel injection pressure to be maintained at the optimum level right across the engine speed range. In addition, selective cutting out of single injectors (Fig. 17) and an optimised exhaust valve timing help to keep smoke emissions below the visible limit at very low speeds.

Sulzer RT-flex engines have been extremely well received by shipowners. The good service experience with the first series-built engine (since September 2001, now more than 14,000 running hours) was closely followed by orders for RT-flex engines. Ordering, however, took off with the recent order boom for very large container liners.

By the end of March 2004, a total of 100 Sulzer RT-flex engines had been built or were on order, aggregating 4.16 million kW. Of these, 59 engines are of the largest size, the Sulzer RT-flex96C. The orders include all the other types in the RT-flex engine programme: the RT-flex50, RT-flex58T-B, RT-flex60C, RT-flex68T-B and RT-flex84T-D types.

Fig. 19: The Enviro Ship concept can be illustrated by the case of a 10,000 TEU container liner powered by a Sulzer 14RT-flex96C common-rail engine with a Total Heat Recovery Plant. [04#052]



Conclusion

This Total Heat Recovery Plant is attracting much attention from shipowners interested in saving fuel costs and reducing CO₂ emissions. It must be remembered that modern large, low-speed engines are very highly developed and there is little potential for achieving significant savings in fuel consumption, and thereby reducing CO₂ emissions by engine developments alone. Yet major improvements can be gained by using proven technology and hardware through applying the Total Heat Recovery Plant. It is thus a practical path forward.

The combination of a Sulzer RT-flex engine with Total Heat Recovery Plant is a major contribution to the Enviro Ship (Fig. 19), creating shipping with much reduced environmental impact.

Acknowledgements

The author thanks ABB Turbo Systems Ltd, Peter Brotherhood Ltd and Siemens for their technical assistance in the preparation of this paper.